



**UNITED NATIONS / DOT
PERFORMANCE CERTIFICATION**

4G DESIGN QUALIFICATION

6 x 2.5 Liter Plastic Bottle Packaging (PT 04003) with

Two Case Sealing Mechanisms:

#1) Taped Top and Bottom Flaps

#2) Taped Top and Glued Bottom Flaps

TEST REPORT #: 09-7150



4G / Y29.1 / S / **

USA / +CC6166

** Insert year the packaging is manufactured

TESTING PERFORMED FOR:

PUREPAK TECHNOLOGY

324 South Braken Lane Suite 3

Chandler, AZ 85224

ATTN: Mike Dodd

TESTING PERFORMED BY:

TEN-E Packaging Services, Inc.

1666 County Road 74

Newport, MN 55055

Phone: (651) 459-0671

Fax: (651) 459-1430

TEN-E Packaging Services, Inc.

326 N. Corona Avenue

Ontario, CA 91764

Phone: (909) 937-1260

Fax: (909) 937-1262

September 17, 2009

TABLE OF CONTENTS

Section I: CERTIFICATION.....	3
Sections II & V: PACKAGING DESCRIPTION / COMPONENT DRAWINGS	4
<i>COMPONENT INFORMATION.....</i>	<i>6</i>
Section III: TEST PROCEDURES AND RESULTS	9
<i>DROP TESTS</i>	
<i>Taped Top and Bottom Flaps</i>	<i>9</i>
<i>DROP TESTS</i>	
<i>Taped Top and Glued Bottom Flaps</i>	<i>10</i>
<i>STACKING & STACKING STABILITY TESTS</i>	
<i>Taped Top and Bottom Flaps</i>	<i>11</i>
<i>STACKING & STACKING STABILITY TESTS</i>	
<i>Taped Top and Glued Bottom Flaps.....</i>	<i>12</i>
<i>PRESSURE DIFFERENTIAL TEST</i>	<i>13</i>
<i>REPETITIVE SHOCK VIBRATION TESTS</i>	
<i>Taped Top and Bottom Flaps.....</i>	<i>14</i>
<i>REPETITIVE SHOCK VIBRATION TESTS</i>	
<i>Taped Top and Glued Bottom Flaps.....</i>	<i>15</i>
<i>COBB WATER ABSORPTION TESTS.....</i>	<i>16</i>
<i>REGULATORY AND INDUSTRY STANDARD REFERENCES</i>	<i>17</i>
Section IV: MATHEMATICAL CALCULATIONS.....	18

SECTION I: CERTIFICATION

**Design Qualification of the PurePak Technology Corporation
6 x 2.5 Liter Plastic Bottle Packaging (PT 04003) with Two Case Sealing Mechanisms:**

#1) Taped Top and Bottom Flaps

#2) Taped Top and Glued Bottom Flaps

TEN-E PACKAGING SERVICES, INC. certifies that the PurePak Technology Corporation packaging referenced above has passed the standards of the DEPARTMENT OF TRANSPORTATION'S TITLE 49 CFR; Performance Oriented Packaging Standards, Section 178. This package is also certified under IMDG, ICAO/IATA Regulations and the UN Recommendations on the Transport of Dangerous Goods. It is the responsibility of the end user to determine authorization for use under these regulations. The use of other packaging methods or components other than those documented in this report may render this certification invalid.

SUMMARY OF PERFORMANCE TESTS

UN /DOT TEST	CFR REFERENCE	TEST LEVEL	TEST CONTENTS	TEST COMPLETED	TEST RESULTS
Drop #1	178.603	1.9m	Methanol/Water	August 4, 2009	PASS
Drop #2	178.603	1.9m	Methanol/Water	August 21, 2009	PASS
Stacking #1	178.606	748.4 Kg – 24 Hrs.	Water	August 4, 2009	PASS
Stacking #2	178.606	748.4 Kg – 24 Hrs.	Water	August 5, 2009	PASS
Pressure	173.27	300kPa – 30 Min.	Water	August 4, 2009	PASS
Vibration #1	178.608	4.0 Hz – 1 Hr.	Water	August 13, 2009	PASS
Vibration #2	178.608	3.8 Hz – 1 Hr.	Water	August 5, 2009	PASS
Cobb	178.516	30 minutes	---	August 6, 2009	PASS
TEST REPORT NUMBERS:			09-7150		
UN MARKING: (CFR 49 - 178.503)				4G / Y29.1 / S / ** USA / +CC6166	
PACKAGING IDENTIFICATION CODE:			4G - Fiberboard Box (178.516)		
PERFORMANCE STANDARD:			Y (Packaging meets Packing Group II and III tests)		
AUTHORIZED GROSS MASS:			29.1 Kg (64.1 Lbs.)		
"S" DESIGNATION:			Denotes Inner Packagings		
YEAR OF MANUFACTURE:			**Insert year the packaging is manufactured		
STATE AUTHORIZING THE MARK:			USA		
PACKAGING CERTIFICATION AGENCY:			(+CC) TEN-E Packaging Services, Inc. (Ontario, CA)		
THIRD PARTY PACKAGE IDENTIFICATION:			+CC6166		
PERIODIC RETEST DATE:			August 21, 2011		

ALL OTHER WARRANTIES, EXPRESSED OR IMPLIED, INCLUDING ANY WARRANTY THAT THE PACKAGING TESTED IS MERCHANTABILITY OR FIT FOR A PARTICULAR PURPOSE, ARE DISCLAIMED. In no event shall TEN-E Packaging Services, Inc. liability exceed the total amount paid by PurePak Technology Corporation for services rendered. In the event of future changes to the above referenced test standard, it is the responsibility of PurePak Technology Corporation to determine whether additional testing or updating of past testing is necessary to verify that the packaging we have tested remains in compliance with those standards.

MANUFACTURER:

PurePak Technology Corporation
324 South Braken Lane Suite 3
Chandler, AZ 85224

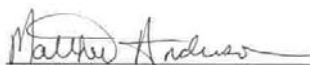

Matthew Anderson
Packaging Engineer
TEN-E Packaging Services, Inc.
326 North Corona Avenue
Ontario, CA 91764

SECTIONS II & V: PACKAGING DESCRIPTION / COMPONENT DRAWINGS

6 x 2.5 Liter Plastic Bottle Packaging (PT 04003) with Taped Top and Bottom Flaps

ASSEMBLY DRAWING

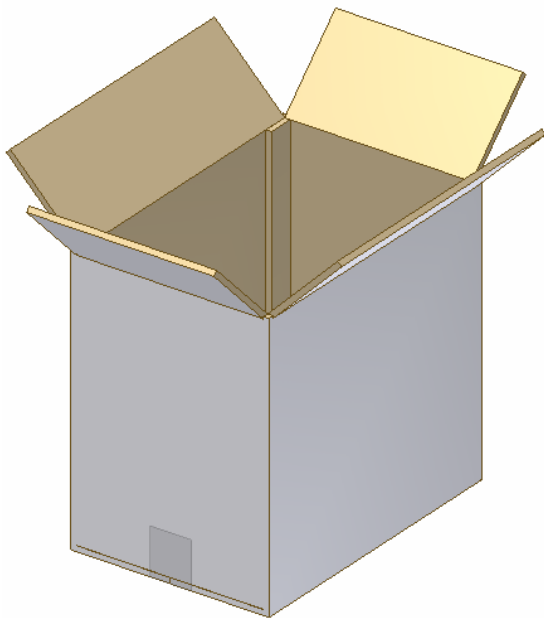

TEST LEVELS

Certification Type:	Design Qualification
Packaging Code Designation:	4G
Packing Group:	II
Specific Gravity:	1.9
Internal Pressure:	300 kpa

TEST SAMPLE PREPARATION
(Refer to Section IV)

Overall Packaging Tare Weight:	1,969 Grams
Inner Packaging Fill Capacity (98% Maximum Capacity):	
Methanol/Water	2,316 Grams
Water	2,387 Grams
Package Test Weight:	
Methanol/Water	15.8 Kg (34.8 Lbs.)
Water	16.2 Kg (35.7 Lbs.)
Authorized Package Gross Mass:	29.1 Kg (64.1 Lbs.)

CLOSING METHODS – INNER PACKAGING

Application Torque	45 In-Lbs
Equipment:	Kaps All Electronic Torque Tester #701

CLOSING METHODS – SHIPPER

Top Flaps:

Type:	Pressure Sensitive Tape
Width:	48 mm (2")
Overlap:	2" Minimum
Tape Pattern:	Center Seam
Inner Flaps:	4-1/2" Width Gap
Outer Flaps:	Meet

Bottom Flaps:

Type:	Pressure Sensitive Tape
Width:	48 mm (2")
Overlap:	2" Minimum
Tape Pattern:	Center Seam
Inner Flaps:	4-1/2" Width Gap
Outer Flaps:	Meet

6 x 2.5 Liter Plastic Bottle Packaging (PT 04003) with Taped Top and Glued Bottom Flaps	
ASSEMBLY DRAWING	TEST LEVELS
	Certification Type: Design Qualification
	Packaging Code Designation: 4G
	Packing Group: II
	Specific Gravity: 1.9
	Internal Pressure: 300 kpa
	TEST SAMPLE PREPARATION (Refer to Section IV)
	Overall Packaging Tare Weight: 1,969 Grams
	Inner Packaging Fill Capacity (98% Maximum Capacity):
	Methanol/Water 2,316 Grams
	Water 2,387 Grams
	Package Test Weight:
	Methanol/Water 15.8 Kg (34.8 Lbs.)
	Water 16.2 Kg (35.7 Lbs.)
	Authorized Package Gross Mass: 29.1 Kg (64.1 Lbs.)
	CLOSING METHODS – INNER PACKAGING
Application Torque 45 In-Lbs	
Equipment: Kaps All Electronic Torque Tester #701	
CLOSING METHODS – SHIPPER	
Top Flaps:	
Type: Pressure Sensitive Tape	
Width: 48 mm (2")	
Overlap: 2" Minimum	
Tape Pattern: Center Seam	
Inner Flaps: 4-1/2" Width Gap	
Outer Flaps: Meet	
Bottom Flaps:	
Type: Hot Glued; Customer Provided	
Inner Flaps: 4-1/2" Width Gap	
Outer Flaps: Meet	

COMPONENT INFORMATION

CLOSURE		Drawing
Manufacturer: PurePak Technology Corporation: Chandler, AZ		
Description:	45mm Threaded Closure Tamper Evident	
Material/Pigment:	Polyethylene / Red	
Density:	0.925 g/cc	
Tare Weight:	10.80 Grams	
Overall Dimensions:		
• Height	1.259"	
• Diameter	1.969"	
Finish Dimensions:		
• T	1.797"	
• E	1.694"	
Markings (QC Audit):	1795 1	
LINER/GASKET		
Description:	Low Density Polyethylene Liner	
Tare Weight:	0.91 Grams	
Thickness:	0.012"	
Diameter:	1.746"	

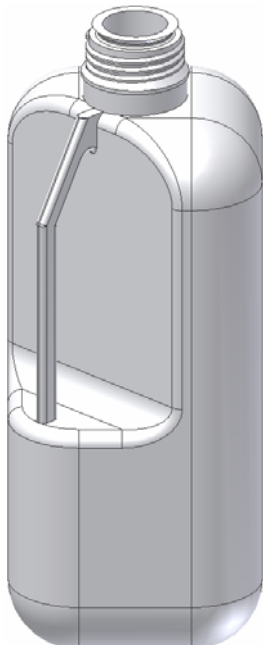
PLASTIC BOTTLE		Drawing
Manufacturer: PurePak Technology Corporation: Chandler, AZ		
Description:	2.5 Liter Plastic Bottle	
Material/Pigment:	High Density Polyethylene, Natural	
Method of Mfgr:	Blow Molded	
Density:	0.945 g/cc	
Melt Index (190/21.6):	17.50 g/cc	
Tare Weight:	208 Grams	
Capacity:		
• Rated	2.5 Liter	
• Overflow	2,436 Grams (82.336 Oz)	
Overall Dimensions:		
• Width:	4.500"	
• Depth:	4.500"	
• Height	11.580"	
Finish Dimensions:		
• T	1.772"	
• E	1.490"	
• Thread Pitch	0.1540"	
Wall Thickness:		
• Minimum	0.037"	
Markings (QC Audit):	4/09 DODD 4 T16 SPI "2" HDPE Recycling Symbol	



SHIPPER		
Manufacturer: Temple-Inland		
Description:	Regular Slotted Container	
Material/Flute (Inner to Outer):	275 Lb. Double Wall Mottled White Corrugated Fiberboard; B/C-Flute	
Basis Weight (Outer to Inner) Lbs./MSF:	42/26/30/26/42	
Measured Basis Weight	40.8/29.1/32.3/28.0/41.0	
Combined Wt. of Facings:	114	
Tare Weight:	644 Grams	
Overall Dimensions	Inside	Outside
• Length	13.75"	14-3/16"
• Width	9"	9-5/8"
• Height	11.875"	13"
Board Caliper (Nominal):	0.269"	
Manufacturer's Joint:	Inside Glued, 1-1/4" Lap	
Markings (QC Audit):	None	







SECTION III: TEST PROCEDURES AND RESULTS

DROP TESTS

Taped Top and Bottom Flaps

TEST INFORMATION	CRITERIA FOR PASSING THE TEST
<p>TEST CONTENTS: Methanol/Water Solution (0.97 SG)</p> <p>SAMPLE PREPARATION: Refer to Section II</p> <p>CONDITIONING: -18°C (0°F), Chamber #201</p> <p>TEST CONTENTS TEMP.: -18.1°C (-0.58°F)</p> <p>DROP HEIGHT: 1.9 Meters (75") (Refer to Section IV)</p> <p>TEST EQUIPMENT: L.A.B. Accu Drop 160 #301</p>	<ul style="list-style-type: none"> • For packaging containing liquid, each packaging does not leak. • There can be no damage to the outer packaging likely to adversely affect safety during transport and there is no leakage of the filling substance from the inner packaging. • Any discharge from a closure is slight and ceases immediately after impact with no further leakage. (§178.603)







DROP ORIENTATIONS & TEST RESULTS

Sample #1: Flat on Bottom	Sample #2: Flat on Top	Sample #3: Flat on Long Side
		
<p>PASS: No leakage or damage.</p>	<p>PASS: No leakage or damage.</p>	<p>PASS: No leakage or damage.</p>
Sample #4: Flat on Short Side	Sample #5: Bottom Corner	*Sample #1: Top Corner
		
<p>PASS: No leakage or damage.</p>	<p>PASS: No leakage. Slight deformation to shipper on impact.</p>	<p>PASS: No leakage. Slight deformation to shipper on impact.</p>

*Sample used for Flat on Bottom Drop is also used for the Top Corner Drop

DROP TESTS **Taped Top and Glued Bottom Flaps**

TEST INFORMATION	CRITERIA FOR PASSING THE TEST
<p>TEST CONTENTS: Methanol/Water Solution (0.97 SG)</p> <p>SAMPLE PREPARATION: Refer to Section II</p> <p>CONDITIONING: -18°C (0°F), Chamber #201</p> <p>TEST CONTENTS TEMP.: -18.1°C (-0.58°F)</p> <p>DROP HEIGHT: 1.9 Meters (75") (Refer to Section IV)</p> <p>TEST EQUIPMENT: L.A.B. Accu Drop 160 #301</p>	<ul style="list-style-type: none"> • For packaging containing liquid, each packaging does not leak. • There can be no damage to the outer packaging likely to adversely affect safety during transport and there is no leakage of the filling substance from the inner packaging. • Any discharge from a closure is slight and ceases immediately after impact with no further leakage. <p style="text-align: right;">(\$178.603)</p>

DROP ORIENTATIONS & TEST RESULTS		
Sample #12: Flat on Bottom	Sample #13: Flat on Top	Sample #14: Flat on Long Side
		
PASS: No leakage or damage.	PASS: No leakage or damage.	PASS: No leakage or damage.
Sample #15: Flat on Short Side	Sample #16: Bottom Corner	*Sample #12: Top Corner
		
PASS: No leakage or damage.	PASS: No leakage. Slight deformation to shipper on impact.	PASS: No leakage. Slight deformation to shipper on impact.

*Sample used for Flat on Bottom Drop is also used for the Top Corner Drop

STACKING & STACKING STABILITY TESTS **Taped Top and Bottom Flaps**

TEST INFORMATION		CRITERIA FOR PASSING THE TEST
<p>TEST CONTENTS: Water</p> <p>SAMPLE PREPARATION: Refer to Section II</p> <p>CONDITIONING: 73°F / 50% RH, Chamber #202</p> <p>TEST LOAD APPLIED: 748.4 Kg (1,650.0 Lbs.) (Refer to Section IV)</p> <p>TEST DURATION: 24 Hours</p> <p>TEST EQUIPMENT: L.A.B. Validator Compression System #403</p>	<ul style="list-style-type: none"> • There must be no leakage of the filling substance from the inner receptacle, or inner packaging. • There can be no deterioration that could adversely affect transport safety or any distortion liable to reduce the package's strength, cause instability in stacks of packages, or cause damage to inner packagings that is likely to reduce safety in transport. <p style="text-align: right;">(\$178.606)</p>	

STACKING TEST SET UP AND RESULTS			
	Sample #	Maximum Deflection After 24 Hours	Results
	6	0.044"	PASS
	7	0.044"	PASS
	8	0.044"	PASS

STACKING STABILITY TEST SET-UP	CRITERIA FOR PASSING THE TEST
	<p>In guided load tests, stacking stability must be assessed after test completion.</p> <ul style="list-style-type: none"> • Two filled packagings of the same type must be placed on the test sample. • The stacked packages must maintain their position for one hour. <p style="text-align: right;">(\$178.606)</p>
PASS	

STACKING & STACKING STABILITY TESTS **Taped Top and Glued Bottom Flaps**

TEST INFORMATION	CRITERIA FOR PASSING THE TEST
TEST CONTENTS: Water SAMPLE PREPARATION: Refer to Section II CONDITIONING: 73°F / 50% RH, Chamber #202 TEST LOAD APPLIED: 748.4 Kg (1,650.0 Lbs.) (Refer to Section IV) TEST DURATION: 24 Hours TEST EQUIPMENT: L.A.B. Validator Compression System #403	<ul style="list-style-type: none"> • There must be no leakage of the filling substance from the inner receptacle, or inner packaging. • There can be no deterioration that could adversely affect transport safety or any distortion liable to reduce the package's strength, cause instability in stacks of packages, or cause damage to inner packagings that is likely to reduce safety in transport. <p style="text-align: right;">(\$178.606)</p>

STACKING TEST SET UP AND RESULTS			
	Sample #	Maximum Deflection After 24 Hours	Results
	9	0.044"	PASS
	10	0.044"	PASS
	11	0.044"	PASS

STACKING STABILITY TEST SET-UP	CRITERIA FOR PASSING THE TEST
 PASS	<p>In guided load tests, stacking stability must be assessed after test completion.</p> <ul style="list-style-type: none"> • Two filled packagings of the same type must be placed on the test sample. • The stacked packages must maintain their position for one hour. <p style="text-align: right;">(\$178.606)</p>

PRESSURE DIFFERENTIAL TEST

TEST INFORMATION		CRITERIA FOR PASSING THE TEST
TEST CONTENTS:	Water	<ul style="list-style-type: none"> • Packaging for which retention of liquid is a basic function must be capable of withstanding the pressure requirements without leakage. (§173.27)
FILL CAPACITY:	Maximum Capacity	
CLOSURE APPLICATION:	Refer to Section II	
CONDITIONING:	Ambient	
TEST PRESSURE:	300kPa	
TEST DURATION:	30 Minutes	
AREA OF PRESSURIZATION:	Through the Bottom Sidewall	
TEST EQUIPMENT:	Regulated Water Source Gauge #602	

HYDROSTATIC PRESSURE TEST SET-UP & RESULTS

	Sample #	Results	Comments / Observations
	1	PASS	All three samples maintained the 300kPa test pressure for 30 minutes without leakage.
	2	PASS	
	3	PASS	

REPETITIVE SHOCK VIBRATION TESTS

Taped Top and Bottom Flaps

TEST INFORMATION	CRITERIA FOR PASSING THE TEST
<p>TEST CONTENTS: Water</p> <p>SAMPLE PREPARATION: Refer to Section II</p> <p>CONDITIONING: 73°F / 50% RH, Chamber #202</p> <p>TABLE DISPLACEMENT: 1"</p> <p>TEST FREQUENCY: 4.0 Hz</p> <p>TEST DURATION: 1 Hour</p> <p>TEST EQUIPMENT: Vertical motion using L.A.B. Palletizer Transportation Simulator #501</p>	<p>Immediately following the period of vibration, each package must be removed from the platform, turned on its side and observed for any evidence of leakage.</p> <ul style="list-style-type: none"> • A packaging passes the vibration test if there is no rupture or leakage from any of the packages. • No test sample should show any deterioration which could adversely affect transportation safety or any distortion liable to reduce packaging strength. (\$178.608)

VIBRATION TEST SET-UP & RESULTS

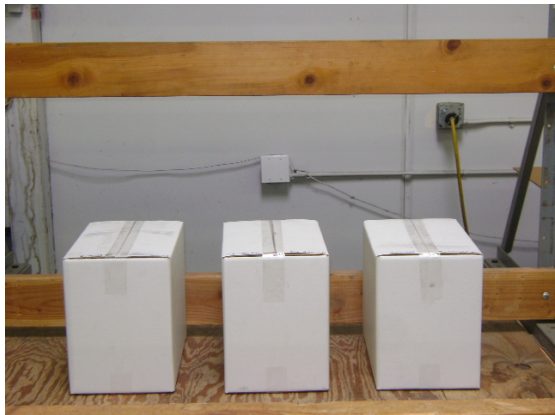
	Sample #	Results	Comments / Observations
	6	PASS	No leakage or damage.
	7	PASS	
	8	PASS	

REPETITIVE SHOCK VIBRATION TESTS

Taped Top and Glued Bottom Flaps

TEST INFORMATION		CRITERIA FOR PASSING THE TEST
TEST CONTENTS:	Water	Immediately following the period of vibration, each package must be removed from the platform, turned on its side and observed for any evidence of leakage. <ul style="list-style-type: none"> • A packaging passes the vibration test if there is no rupture or leakage from any of the packages. • No test sample should show any deterioration which could adversely affect transportation safety or any distortion liable to reduce packaging strength. (\$178.608)
SAMPLE PREPARATION:	Refer to Section II	
CONDITIONING:	73°F / 50% RH, Chamber #202	
TABLE DISPLACEMENT:	1"	
TEST FREQUENCY:	4.0 Hz	
TEST DURATION:	1 Hour	
TEST EQUIPMENT:	Vertical motion using L.A.B. Palletizer Transportation Simulator #501	

VIBRATION TEST SET-UP & RESULTS

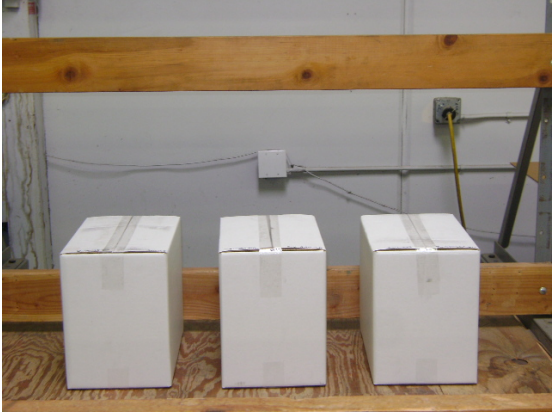
	Sample #	Results	Comments / Observations
	9	PASS	No leakage or damage.
	10	PASS	
	11	PASS	

COBB WATER ABSORPTION TESTS

TEST INFORMATION		CRITERIA FOR PASSING THE TEST
SAMPLE SIZE:	(5) 5" x 5" Squares	<ul style="list-style-type: none"> An increase in mass greater than 155 g/m² over the 30 minute duration represents an unacceptable level of water resistance. (§178.516)
CONDITIONING:	73°F / 50% RH, Chamber #202	
WATER APPLIED:	100mL / Sample	
TEST DURATION:	30 Minutes / Sample	
TEST EQUIPMENT:	UWE Analytical Balance #102 Gurley Cobb Water Absorption Apparatus	

COBB WATER ABSORPTION TEST RESULTS	
Sample #	Water Absorbed (g/m²)
1	105 g/m²
2	127 g/m²
3	109 g/m²
4	108 g/m²
5	114 g/m²
AVERAGE:	112.6 g/m²
RESULT	PASS

REGULATORY AND INDUSTRY STANDARD REFERENCES

REGULATORY REFERENCES

TEST	49 CFR ^① 2008 Edition	UN ^② 15th Edition	IMDG ^③ 2008 Edition	ICAO ^④ 09-10 Edition	IATA ^⑤ 50th Edition
Drop:	178.603	6.1.5.3	6.1.5.3	6; 4.3	6.3.3
Stacking:	178.606	6.1.5.6	6.1.5.6	6; 4.6	6.3.6
Pressure:	173.27(c)	4.1.1.4.1	---	4; 1.1.6	5.0.2.9
Vibration:	178.608	---	---	4; 1.1.1	5.0.2.7
Cobb:	178.516	6.1.4.12.1	6.1.4.12.1	6; 3.1.11.1	6.2.12.2

- ① United States Department of Transportation Code of Federal Regulations (CFR) Title 49, Transportation, Parts 100-199
- ② The United Nations Recommendations on the Transport of Dangerous Goods — Model Regulations. (UN – Orange Book)
- ③ International Maritime Dangerous Goods Code (IMDG)
- ④ Technical Instructions for the Safe Transport of Dangerous Goods by Air (ICAO)
- ⑤ International Air Transport Association (IATA) Dangerous Goods Regulations

INDUSTRY STANDARD REFERENCES

Drop:	ASTM ^⑥ D5276:	Standard Test Method for Drop Test of Loaded Containers by Free Fall
	ISO ^⑦ 2248:	Packaging – Complete, Filled Transport Packages – Vertical Impact Test By Dropping
Stacking:	ASTM ^⑥ D4577:	Standard Test Method for Compression Resistance of a Container Under Constant Load
	ISO ^⑦ 2234:	Packaging – Complete, Filled Transport Packages – Stacking Tests using Static Load
Vibration:	ASTM ^⑥ D999:	Standard Test Method for Vibration Testing of Shipping Containers
	ISO ^⑦ 2247:	Packaging – Complete, Filled transport Packages – Vibration Test at Fixed Low Frequency
Cobb:	ISO ^⑦ 535:	Paper and Board - Determination of Water Absorption - Cobb Method

⑥ American Society for Testing and Materials (ASTM)

⑦ International Organization for Standardization (ISO)

EQUIPMENT

All inspection, measuring and test equipment that can affect product quality is calibrated and adjusted at prescribed intervals, or prior to use, and is traceable to NIST, using ANSI Z540 as an overall guide for calibration certification.

SECTION IV: MATHEMATICAL CALCULATIONS

INFORMATION USED FOR CALCULATIONS

Overall Package Tare Weight (PTW):	1,969 Grams	
Overflow Capacity (OFC):		Methanol/Water SG
Methanol/Water	2,363 Grams	SG: 0.970
Water	2,436 Grams	
Number of Inner Packagings (# IP):	6	
Packing Group	II	
Product Specific Gravity (PSG):	1.9	
Packing Group Multiplication Factor (MF):	1.00	
Overall Height of one Package (OH):	13.00 Inches	
Stack Test-# of Samples Tested Simultaneously:	3	

98% OF OVERFLOW

Overflow Capacity (OFC) x 98%

<u>OFC</u>	x	<u>98%</u>		
2,363	x	98% =	2,316 Grams	Methanol/Water
2,436	x	98% =	2,387 Grams	Water

PACKAGE TEST WEIGHTS

Overall Pkg Tare Weight (PTW) + (98% Overflow Capacity (OFC) x # of Inner Pkg (# IP))

<u>PTW</u>	+	<u>(98% OFC)</u>	x	<u># IP)</u>	
1,969	+	2,316	x	6	Methanol/Water
1,969	+	2,387	x	6	Water
Methanol/Water:		15.8	Kg	34.8	Lbs.
Water:		16.2	Kg	35.7	Lbs.

AUTHORIZED PACKAGE GROSS MASS CALCULATION (APGM)

Overall Pkg Tare Weight (PTW) + (Product SG (PSG) x 98% Overflow (OFC) x # of Inner Pkg (# IP))

<u>PTW</u>	+	<u>(PSG</u>	x	<u>98% OFC</u>	x	<u># IP)</u>
1,969	+	1.9	x	2,387	x	6
		29.1	Kg	64.1	Lbs.	

DROP HEIGHT				
Calculation For Product Specific Gravities Exceeding 1.2				
Product Specific Gravity (PSG) x Packing Group Multiplication Factor (MF)				
PSG	x	MF	Packing Group: II	
1.9	x	1.00	Required Drop Height	Actual Drop Height
		1.90 Meter	74.8 Inches	75 Inches

STACKING TEST MINIMUM LOAD CALCULATIONS				
Number of Packages in a 3m High Stack (118 / Overall Pkg Height (OH) -1)				
118 / Overall Height of one Pkg (OH) - 1				
(118	/	OH)	-1	= # 3m HS
118	/	13.00	-1	= 8.1
Stacking Test Load Calculation (Individual Package)				
Authorized Pkg Gross Mass (APGM) x # of Pkg in a 3m High Stack (# 3m HS)				
APGM	x	# 3m HS		
29.1	x	8.1		
		235.7 Kg		519.6 Lbs.

Stacking Test Load Calculation				
Samples x Authorized Pkg Gross Mass (APGM) x # of Pkg in a 3m High Stack (# 3m HS)				
Samples	x	(APGM	x	# 3m HS)
3	x	29.1	x	8.1
		707.1 Kg		1,558.9 Lbs.