

**UNITED NATIONS / DOT
PERFORMANCE CERTIFICATION**



4G DESIGN QUALIFICATION

**6 x 500 mL Round Plastic Bottle Packaging with
Two Neck Finishes:
#1) 38-439 Neck Finish & #2) 45mm Neck Finish**

TEST REPORT #: 16-CA20163

 4G / Y7.5 / S / **
USA / +CC7197

**Insert the year packaging is manufactured

TESTING PERFORMED FOR:

PUREPAK TECHNOLOGY CORPORATION

324 South Bracken Lane
Suite 3
Chandler, AZ 85224

ATTN: Michael Dodd

TESTING PERFORMED BY:

TEN-E PACKAGING SERVICES, INC.

326 North Corona Avenue
Ontario, CA 91764
Phone: 909-937-1260
Fax: 909-937-1262

October 20, 2016

TABLE OF CONTENTS

SECTION I: CERTIFICATION 3
SECTIONS II & V: PACKAGING DESCRIPTIONS / COMPONENT DRAWINGS 4
 COMPONENT INFORMATION 6
SECTION III: TEST PROCEDURES AND RESULTS 9
 DROP TESTS 38-439 Neck Finish 9
 DROP TESTS 45mm Neck Finish 10
 STACKING & STACKING STABILITY TESTS 38-439 Neck Finish 11
 STACKING & STACKING STABILITY TESTS 45mm Neck Finish 12
 PRESSURE DIFFERENTIAL TEST 38-439 Neck Finish 13
 PRESSURE DIFFERENTIAL TEST 45mm Neck Finish 14
 VIBRATION TEST 38-439 Neck Finish 15
 VIBRATION TEST 45mm Neck Finish 16
 COBB WATER ABSORPTION TEST 17
REGULATORY AND INDUSTRY STANDARD REFERENCES 18
SECTION IV: MATHEMATICAL CALCULATIONS 38mm 19
SECTION IV: MATHEMATICAL CALCULATIONS 45mm 21

NOTES AND COMMENTS

Tested as a design qualification due to a change in the corrugated basis weight. The packaging will retain the +CC7197 Identification.

This package uses special permit DOT-SP 14656 which authorizes the manufacture, mark, sale and use of non-DOT specification combination packaging for the transportation in commerce of the materials authorized by this special permit.

SECTION I: CERTIFICATION

**Design Qualification of the PurePak Technology Corporation
 6 x 500 mL Round Plastic Bottle Packaging with Two Neck Finishes:
 #1) 38-439 Neck Finish & #2) 45mm Neck Finish**

TEN-E Packaging Services, Inc. is a current DOT UN Third-Party Certification Agency under §107.403 and certifies that the **PurePak Technology Corporation** packaging referenced above has passed the standards of the DEPARTMENT OF TRANSPORTATION'S TITLE 49 CFR; Performance Oriented Packaging Standards, Section 178. This package is also certified under IMDG, ICAO/IATA Regulations and the UN Recommendations on the Transport of Dangerous Goods. It is the responsibility of the end user to determine authorization for use under these regulations. The use of other packaging methods or components other than those documented in this report may render this certification invalid.

SUMMARY OF PERFORMANCE TESTS

UN / DOT TEST	CFR REFERENCE	TEST LEVEL	TEST CONTENTS	TEST COMPLETED	TEST RESULTS
Drop	178.603	1.9 m	Methanol/Water Solution	September 21, 2016	PASS
Stacking	178.606	317.5 Kg – 24 Hours	Water	September 20, 2016	PASS
Pressure	173.27	300 kPa - 30 Minutes	Water	September 23, 2016	PASS
Vibration	178.608	3.7 Hz – 1 Hour	Water	September 22, 2016	PASS
Cobb	178.516	30 Minutes	---	October 20, 2016	PASS
TEST REPORT NUMBER:		16-CA20163			
UN MARKING: (CFR 49 – 178.503)		 4G / Y7.5 / S / ** USA / +CC7197			
PACKAGING IDENTIFICATION CODE:		4G - Fiberboard Box (178.516)			
PERFORMANCE STANDARD:		Y (Packaging meets Packing Group II and III tests)			
AUTHORIZED GROSS MASS:		7.5 Kg (16.5 Lbs.)			
"S" DESIGNATION:		Denotes Inner Packagings			
YEAR OF MANUFACTURE:		** Insert year the packaging is manufactured			
STATE AUTHORIZING THE MARK:		USA			
PACKAGING CERTIFICATION AGENCY:		(+CC) TEN-E Packaging Services, Inc. (Ontario, CA CAA #2006030021)			
THIRD PARTY PACKAGING IDENTIFICATION:		+CC7197			
PERIODIC RETEST DATE:		October 20, 2018			
SP NUMBER:		DOT-SP 14656			

ALL OTHER WARRANTIES, EXPRESSED OR IMPLIED, INCLUDING ANY WARRANTY THAT THE PACKAGING TESTED IS MERCHANTABLE OR FIT FOR A PARTICULAR PURPOSE, ARE DISCLAIMED. In no event shall TEN-E Packaging Services, Inc. liability exceed the total amount paid by **PurePak Technology Corporation** for services rendered. In the event of future changes to the above referenced test standards, it is the responsibility of **PurePak Technology Corporation** to determine whether additional testing or updating of past testing is necessary to verify that the packaging we have tested remains in compliance with those standards.

MANUFACTURER:

PurePak Technology Corporation
 324 South Bracken Lane
 Suite 3
 Chandler, AZ 85224

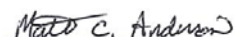
 Matt C. Anderson
 Project Manager
 TEN-E Packaging Services, Inc.

SECTIONS II & V: PACKAGING DESCRIPTIONS / COMPONENT DRAWINGS

6 x 500 mL Round Plastic Bottle Packaging with 38-439 Neck Finish

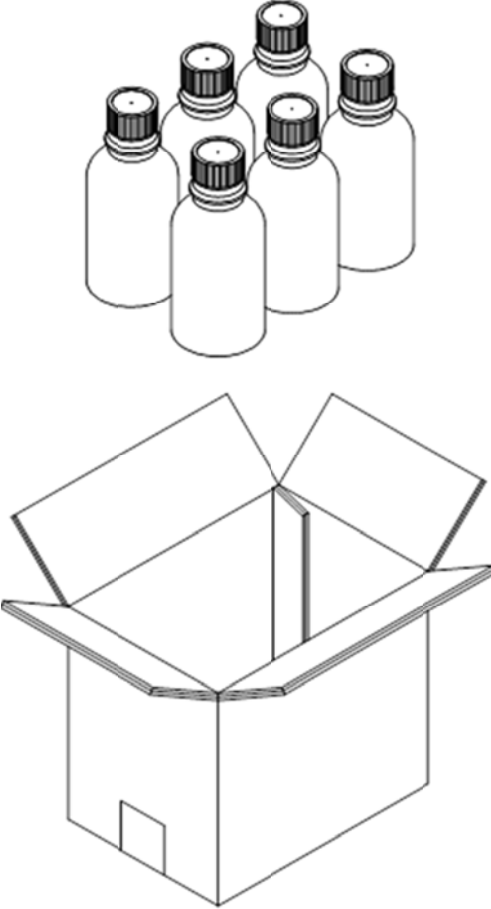
ASSEMBLY DRAWING	TEST LEVELS		
	Certification Type:	Design Qualification	
	Packaging Code Designation:	4G	
	Packing Group:	II	
	Specific Gravity:	1.9	
	Internal Pressure:	300 kPa	
	TEST SAMPLE PREPARATION (Refer to Section IV)		
	Overall Packaging Tare Weight:	625.0 Grams	
	Fill Capacity (98% Maximum Capacity):		
	Methanol/Water Solution	579.1 Grams	
	Water	609.6 Grams	
	Package Test Weight:		
	Methanol/Water Solution	4.0 Kg	8.8 Lbs.
	Water	4.2 Kg	9.2 Lbs.
	Authorized Package Gross Mass:	7.5 Kg	16.5 Lbs.
	CLOSING METHODS – INNER PACKAGING		
	Application Torque:	50 In-Lbs.	
	Equipment:	Kaps All Electronic Torque Tester #W701	
	CLOSING METHODS – SHIPPER		
Top Flaps:			
Manufacturer:	3M, St. Paul, MN		
Type:	3M #34508 Scotch Pressure Sensitive Tape		
Width:	48 mm (2")		
Overlap:	2" Minimum		
Tape Pattern:	Center Seam		
Inner Flaps:	3-1/8" Width Gap		
Outer Flaps:	Meet		
Bottom Flaps:			
Manufacturer:	3M, St. Paul, MN		
Type:	3M #34508 Scotch Pressure Sensitive Tape		
Width:	48 mm (2")		
Overlap:	2" Minimum		
Tape Pattern:	Center Seam		
Inner Flaps:	3-1/8" Width Gap		
Outer Flaps:	Meet		

For Packagings with an Established Gross Mass:

If the gross mass calculation in this report exceeds the previously established gross mass, the manufacturer may elect to maintain the current gross mass marking (e.g. the gross mass rating of the UN marking on the packaging may be less than the calculated gross mass indicated in this report) or use the newly established gross mass. In no event shall the gross mass marking on the packaging exceed the gross mass to which the packaging was tested.

6 x 500 mL Round Plastic Bottle Packaging with 45mm Neck Finish

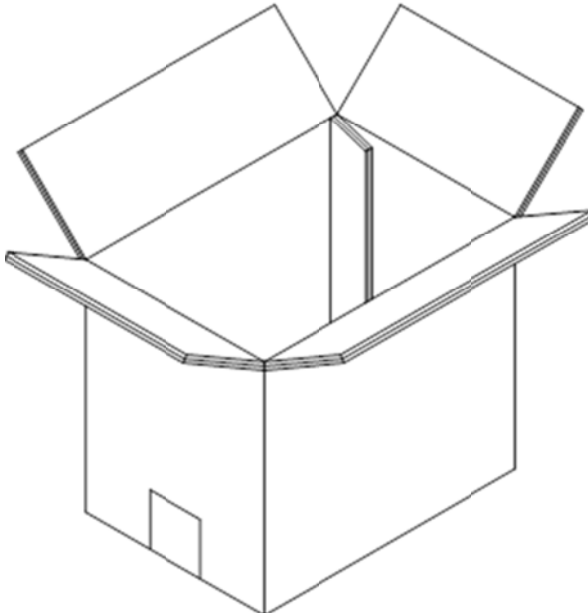
ASSEMBLY DRAWING	TEST LEVELS		
	Certification Type:	Design Qualification	
	Packaging Code Designation:	4G	
	Packing Group:	II	
	Specific Gravity:	1.9	
	Internal Pressure:	300 kPa	
	TEST SAMPLE PREPARATION (Refer to Section IV)		
	Overall Packaging Tare Weight:	612.0 Grams	
	Fill Capacity (98% Maximum Capacity):		
	Methanol/Water Solution	590.3 Grams	
	Water	621.4 Grams	
	Package Test Weight:		
	Methanol/Water Solution	4.1 Kg	9.0 Lbs.
	Water	4.3 Kg	9.4 Lbs.
	Authorized Package Gross Mass:	7.6 Kg	16.7 Lbs.
	CLOSING METHODS – INNER PACKAGING		
	Application Torque:	25 In-Lbs.	
	Equipment:	Kaps All Electronic Torque Tester #W701	
	CLOSING METHODS – SHIPPER		
	Top Flaps:		
	Manufacturer:	3M, St. Paul, MN	
	Type:	3M #34508 Scotch Pressure Sensitive Tape	
	Width:	48 mm (2")	
	Overlap:	2" Minimum	
	Tape Pattern:	Center Seam	
	Inner Flaps:	3-1/8" Width Gap	
	Outer Flaps:	Meet	
	Bottom Flaps:		
	Manufacturer:	3M, St. Paul, MN	
Type:	3M #34508 Scotch Pressure Sensitive Tape		
Width:	48 mm (2")		
Overlap:	2" Minimum		
Tape Pattern:	Center Seam		
Inner Flaps:	3-1/8" Width Gap		
Outer Flaps:	Meet		

For Packagings with an Established Gross Mass:

If the gross mass calculation in this report exceeds the previously established gross mass, the manufacturer may elect to maintain the current gross mass marking (e.g. the gross mass rating of the UN marking on the packaging may be less than the calculated gross mass indicated in this report) or use the newly established gross mass. In no event shall the gross mass marking on the packaging exceed the gross mass to which the packaging was tested.

COMPONENT INFORMATION

CLOSURE (20038485)		DRAWING
Manufacturer: Berry Plastics, Evansville, IN (QIM-317-4937)		
Description:	38mm Threaded Closure	
Quantity:	6	
Material:	Polypropylene	
Tare Weight:	10.17 Grams	
Overall Dimensions:		
• Height	1.016" ± 0.015"	
• Diameter	1.701" ± 0.015"	
Thread:		
• Type	38mm	
• Style	439	
Finish Dimensions:		
• T	1.483" ± 0.007"	
• E	1.389" ± 0.007"	
Markings (QC Audit):	63A	
Liner:		
Description:	P.E. Foam Liner	
Tare Weight:	52 Grams	
Thickness:	0.055"	
Diameter:	1.379"	
PLASTIC BOTTLE (1046059)		
Manufacturer: PurePak Technology, Chandler, AZ (ZB38RD500H)		
Description:	500mL Plastic Bottle	
Quantity:	6	
Material/Pigment:	High Density Polyethylene / Natural	
Method of Manufacture:	Blow Molded	
Tare Weight:	52.0 Grams	
Capacity:		
• Rated	500mL	
• Overflow	622.0 Grams (21.0 Oz)	
Overall Dimensions:		
• Height	7.000" ± 0.060"	
• Diameter	3.071" ± 0.060"	
Thread Dimensions:		
• T	1.461" ± 0.010"	
• E	1.374" ± 0.010"	
• Pitch	0.1640"	
Wall Thickness:		
• Minimum	0.027"	
Markings (QC Audit):	1 9/15 SPI "2" HDPE Recycling Symbol	

CLOSURE (21451022)		DRAWING
Manufacturer: George MENSHEN GmbH, Finnentrop, Germany (DIN 16901-150)		
Description:	45mm Threaded Closure	
Quantity:	6	
Material:	Polyethylene	
Tare Weight:	11.07 Grams	
Overall Dimensions:		
• Height	30.3mm	
• Diameter	51.3mm	
Thread:		
• Type	45mm	
• Style	Buttress	
Finish Dimensions:		
• T	1.785"	
• E	1.662"	
• Thread Pitch	4mm	
Markings (QC Audit):	2817.1 2	
Liner:		
Description:	PTFE Liner	
Tare Weight:	0.91 Grams	
Thickness:	0.008"	
Diameter:	1.793"	
PLASTIC BOTTLE (1046096)		
Manufacturer: PurePak Technology, Chandler, AZ		
Description:	500mL Plastic Bottle	
Quantity:	6	
Material/Pigment:	High Density Polyethylene / Natural	
Method of Manufacture:	Blow Molded	
Tare Weight:	50.0 Grams	
Capacity:		
• Rated	500mL	
• Overflow	634.0 Grams (21.4 Oz)	
Overall Dimensions:		
• Height	7.000" ± 0.060"	
• Diameter	3.071" ± 0.060"	
Thread Dimensions:		
• T	1.772" ± 0.010"	
• E	1.644" ± 0.010"	
• Pitch	0.1587"	
Wall Thickness:		
• Minimum	0.025"	
Markings (QC Audit):	1/15 1 SPI "2" HDPE Recycling Symbol	

SHIPPER

Manufacturer: Smurfit Kappa, Chandler, AZ	
Description:	Regular Slotted Container
Material/Flute (Inner to Outer):	275 Lb. Test Double Wall Natural Kraft Corrugated Fiberboard; B/C-Flute
Basis Weight (Outer to Inner) Lbs./MSF:	
• Specification	42 / 23 / 33 / 23 / 42
Tare Weight:	250.0 Grams







DIMENSIONS

	Specification Dimensions (Inside)	Measured Dimensions (Outside)
• Length	9-3/8"	9-7/8"
• Width	6-5/16"	7"
• Height	7-1/8"	8-1/2"
Board Caliper (Nominal):	0.265"	
Manufacturer's Joint:	Inside Glued, 1-1/4" Lap	
No Box Manufacturer's Certification:		
Markings (QC Audit):	NONE	

SECTION III: TEST PROCEDURES AND RESULTS

DROP TESTS

38-439 Neck Finish

TEST INFORMATION		TEST CRITERIA
TEST CONTENTS:	Methanol/Water Solution (0.950 SG)	<ul style="list-style-type: none"> For packaging containing liquid, each packaging does not leak. There can be no damage to the outer packaging likely to adversely affect safety during transport. Inner receptacles, inner packagings or articles must remain completely within the outer packaging and there must be no leakage of the filling substance from the inner packaging. Any discharge from a closure is slight and ceases immediately after impact with no further leakage. (§178.603)
SAMPLE PREPARATION:	Refer to Section II	
CONDITIONING:	-18°C (0°F) Freezer #W201	
CONTENTS TEMP.:	-18.9°C (-2.0°F)	
DROP HEIGHT:	1.9 Meters (75.0") (Refer to Section IV)	
TEST EQUIPMENT:	L.A.B. Accu Drop 160	
DROP ORIENTATIONS AND TEST RESULTS		
Sample #1: Flat on Bottom	Sample #2: Flat on Top	*Sample #3: Flat on Long Side
		
PASS: No leakage or damage.	PASS: No leakage or damage.	PASS: No leakage or damage.
*Sample #4: Flat on Short Side	*Sample #5: Bottom Corner	**Sample #1: Top Corner
		
PASS: No leakage or damage.	PASS: No leakage. Deformation to shipper on impact.	PASS: No leakage. Deformation to shipper on impact.

*Side and corner drops were conducted to impact the manufacturer's joint.







**Flat on bottom drop sample was also used for the top corner drop.

DROP TESTS

45mm Neck Finish

TEST INFORMATION		TEST CRITERIA
TEST CONTENTS:	Methanol/Water Solution (0.950 SG)	<ul style="list-style-type: none"> For packaging containing liquid, each packaging does not leak. There can be no damage to the outer packaging likely to adversely affect safety during transport. Inner receptacles, inner packagings or articles must remain completely within the outer packaging and there must be no leakage of the filling substance from the inner packaging. Any discharge from a closure is slight and ceases immediately after impact with no further leakage. (§178.603)
SAMPLE PREPARATION:	Refer to Section II	
CONDITIONING:	-18°C (0°F) Freezer #W201	
CONTENTS TEMP.:	-18.9°C (-2.0°F)	
DROP HEIGHT:	1.9 Meters (75.0") (Refer to Section IV)	
TEST EQUIPMENT:	L.A.B. Accu Drop 160	

DROP ORIENTATIONS AND TEST RESULTS

Sample #12: Flat on Bottom	Sample #13: Flat on Top	*Sample #14: Flat on Long Side
		
PASS: No leakage or damage.	PASS: No leakage or damage.	PASS: No leakage or damage.
*Sample #15: Flat on Short Side	*Sample #16: Bottom Corner	**Sample #12: Top Corner
		
PASS: No leakage or damage.	PASS: No leakage. Deformation to shipper on impact.	PASS: No leakage. Deformation to shipper on impact.

*Side and corner drops were conducted to impact the manufacturer's joint.

**Flat on bottom drop sample was also used for the top corner drop.

STACKING & STACKING STABILITY TESTS

38-439 Neck Finish

TEST INFORMATION		TEST CRITERIA
TEST CONTENTS:	Water	<ul style="list-style-type: none"> • There must be no leakage of the filling substance from the inner receptacle, or inner packaging. • There can be no deterioration that could adversely affect transport safety or any distortion liable to reduce the package's strength, cause instability in stacks of packages, or cause damage to inner packagings that is likely to reduce safety in transport. <p>(§178.606)</p>
SAMPLE PREPARATION:	Refer to Section II	
CONDITIONING:	73°F / 50% RH Quality Room #W202	
TEST LOAD APPLIED:	317.5 Kg (700.0 Lbs.) (Refer to Section IV)	
TEST DURATION:	24 Hours	
TEST EQUIPMENT:	TLS Validator Compression System	

STACKING TEST SET-UP & RESULTS

	Sample #	Maximum Deflection After 24 Hours	Results
	6	0.131"	PASS
	7	0.131"	PASS
	8	0.131"	PASS

Comments/Observations: Following the 24-hour stack test, there was no leakage of contents from the test samples and no damage likely to affect the performance of the packaging.

STACKING STABILITY TEST SET-UP & RESULTS

	Results	CRITERIA FOR PASSING THE TEST
	PASS	<ul style="list-style-type: none"> • In guided load tests, stacking stability must be assessed after test completion. • Two filled packagings of the same type must be placed on the test sample. • The stacked packages must maintain their position for one hour. <p>(§178.606)</p>

For stack stability, TEN-E places the filled samples one on top of the other. The bottom sample is rotated to the top until all three samples have been subjected to stacking stability for one hour each.

STACKING & STACKING STABILITY TESTS

45mm Neck Finish

TEST INFORMATION		TEST CRITERIA
TEST CONTENTS:	Water	<ul style="list-style-type: none"> There must be no leakage of the filling substance from the inner receptacle, or inner packaging. There can be no deterioration that could adversely affect transport safety or any distortion liable to reduce the package's strength, cause instability in stacks of packages, or cause damage to inner packagings that is likely to reduce safety in transport. (§178.606)
SAMPLE PREPARATION:	Refer to Section II	
CONDITIONING:	73°F / 50% RH Quality Room #W202	
TEST LOAD APPLIED:	317.5 Kg (700.0 Lbs.) (Refer to Section IV)	
TEST DURATION:	24 Hours	
TEST EQUIPMENT:	L.A.B. 5250 Compression System	

STACKING TEST SET-UP & RESULTS

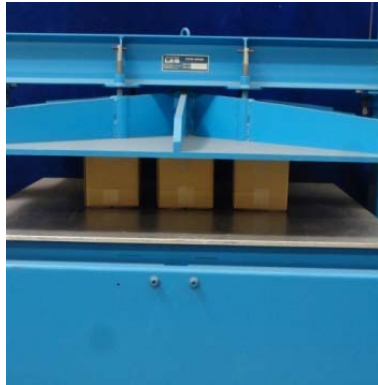
	Sample #	Maximum Deflection After 24 Hours	Results
	17	0.106"	PASS
	18	0.106"	PASS
	19	0.106"	PASS

Comments/Observations: Following the 24-hour stack test, there was no leakage of contents from the test samples and no damage likely to affect the performance of the packaging.

STACKING STABILITY TEST SET-UP & RESULTS

	Results	CRITERIA FOR PASSING THE TEST
	PASS	<ul style="list-style-type: none"> In guided load tests, stacking stability must be assessed after test completion. Two filled packagings of the same type must be placed on the test sample. The stacked packages must maintain their position for one hour. (§178.606)

For stack stability, TEN-E places the filled samples one on top of the other. The bottom sample is rotated to the top until all three samples have been subjected to stacking stability for one hour each.

PRESSURE DIFFERENTIAL TEST

38-439 Neck Finish

TEST INFORMATION		TEST CRITERIA
TEST CONTENTS:	Water	<ul style="list-style-type: none"> Packaging for which retention of liquid is a basic function must be capable of withstanding the pressure requirements without leakage. (§173.27(c))
FILL CAPACITY:	Maximum Capacity	
CLOSURE APPLICATION:	Refer to Section II	
CONDITIONING:	Ambient	
TEST PRESSURE:	300 kPa	
TEST DURATION:	30 Minutes	
AREA OF PRESSURIZATION:	Through the Bottom	
TEST EQUIPMENT:	Regulated Water Source Digital Pressure Gauge #: 605	

HYDROSTATIC PRESSURE TEST SET-UP AND RESULTS

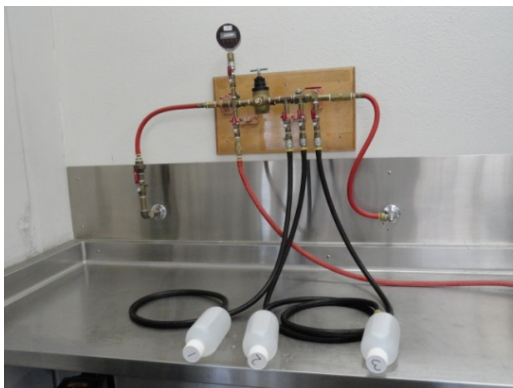
	Sample #	Results	Comments/Observations
	1	PASS	All three samples maintained the 300 kPa test pressure for 30 minutes without leakage.
	2	PASS	
	3	PASS	

PRESSURE DIFFERENTIAL TEST

45mm Neck Finish

TEST INFORMATION		TEST CRITERIA
TEST CONTENTS:	Water	<ul style="list-style-type: none"> Packaging for which retention of liquid is a basic function must be capable of withstanding the pressure requirements without leakage. (§173.27(c))
FILL CAPACITY:	Maximum Capacity	
CLOSURE APPLICATION:	Refer to Section II	
CONDITIONING:	Ambient	
TEST PRESSURE:	300 kPa	
TEST DURATION:	30 Minutes	
AREA OF PRESSURIZATION:	Through the Bottom	
TEST EQUIPMENT:	Regulated Water Source Digital Pressure Gauge #: 605	

HYDROSTATIC PRESSURE TEST SET-UP AND RESULTS

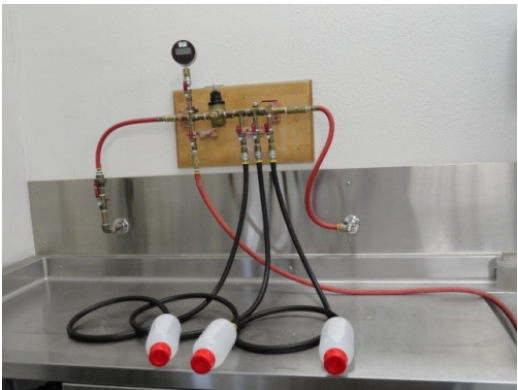
	Sample #	Results	Comments/Observations
	1	PASS	All three samples maintained the 300 kPa test pressure for 30 minutes without leakage.
	2	PASS	
	3	PASS	

VIBRATION TEST

38-439 Neck Finish

TEST INFORMATION		TEST CRITERIA
TEST CONTENTS:	Water	<ul style="list-style-type: none"> Immediately following the period of vibration, each package must be removed from the platform, turned on its side and observed for any evidence of leakage. A packaging passes the vibration test if there is no rupture or leakage from any of the packages. No test sample should show any deterioration which could adversely affect transportation safety or any distortion liable to reduce packaging strength. (§178.608)
SAMPLE PREPARATION:	Refer to Section II	
CONDITIONING:	73°F / 50% RH Quality Room #W202	
TABLE DISPLACEMENT:	1"	
TEST FREQUENCY:	3.7 Hz	
TEST DURATION:	1 Hour	
TEST EQUIPMENT:	Vertical motion using L.A.B. Palletizer Vibration System	

VIBRATION TEST SET-UP AND RESULTS

	Sample #	Results	Comments/Observations
	9	PASS	No leakage or damage.
	10	PASS	
	11	PASS	

VIBRATION TEST

45mm Neck Finish

TEST INFORMATION		TEST CRITERIA
TEST CONTENTS:	Water	<ul style="list-style-type: none"> Immediately following the period of vibration, each package must be removed from the platform, turned on its side and observed for any evidence of leakage. A packaging passes the vibration test if there is no rupture or leakage from any of the packages. No test sample should show any deterioration which could adversely affect transportation safety or any distortion liable to reduce packaging strength. (§178.608)
SAMPLE PREPARATION:	Refer to Section II	
CONDITIONING:	73°F / 50% RH Quality Room #W202	
TABLE DISPLACEMENT:	1"	
TEST FREQUENCY:	3.7 Hz	
TEST DURATION:	1 Hour	
TEST EQUIPMENT:	Vertical motion using L.A.B. Palletizer Vibration System	

VIBRATION TEST SET-UP AND RESULTS

	Sample #	Results	Comments/Observations
	20	PASS	No leakage or damage.
	21	PASS	
	22	PASS	

COBB WATER ABSORPTION TEST

TEST INFORMATION		TEST CRITERIA
NUMBER OF SAMPLES:	5	<ul style="list-style-type: none"> An increase in mass greater than 155 g/m² over the 30 minute duration represents an unacceptable level of water resistance. (§178.516)
SAMPLE SIZE:	5" x 5" (Minimum)	
CONDITIONING:	73°F / 50% RH Quality Room #W202	
WATER APPLIED:	100 mL / Sample	
TEST DURATION:	30 Minutes / Sample	
TEST EQUIPMENT:	UWE Analytical Balance Gurley Cobb Water Absorption Fixtures	

COBB WATER ABSORPTION TEST RESULTS	
Sample #	Water Absorbed
1	93.0 g/m ²
2	90.0 g/m ²
3	118.0 g/m ²
4	92.0 g/m ²
5	101.0 g/m ²
AVERAGE:	98.8 g/m²
RESULT	PASS

REGULATORY AND INDUSTRY STANDARD REFERENCES

REGULATORY REFERENCES

TEST	49 CFR ^①	UN ^②	IMDG ^③	ICAO ^④	IATA ^⑤
	October 2015 Edition	19 th Edition	2014 Edition	2015-2016 Edition	57th Edition
Drop:	178.603	6.1.5.3	6.1.5.3	6; 4.3	6.3.3
Stacking:	178.606	6.1.5.6	6.1.5.6	6; 4.6	6.3.6
Pressure:	173.27(c)	4.1.1.4.1	4.1.1.4.1	4; 1.1.6	5.0.2.9
Vibration:	178.608	---	---	4; 1.1.1	5.0.2.7
Cobb:	178.516(b)(1)	6.1.4.12.1	6.1.4.12.1	6; 3.1.11.1	6.2.12.2

- ① United States Department of Transportation Code of Federal Regulations (CFR) Title 49, Transportation, Parts 100-185
 ② The United Nations Recommendations on the Transport of Dangerous Goods – Model Regulations (UN – Orange Book)
 ③ International Maritime Dangerous Goods Code (IMDG)
 ④ Technical Instructions for the Safe Transport of Dangerous Good by Air (ICAO)
 ⑤ International Air Transport Association (IATA) Dangerous Goods Regulations

INDUSTRY STANDARD REFERENCES

Drop:	ASTM ^⑥ D5276:	Standard Test Method for Drop Test of Loaded Containers by Free Fall
	ASTM ^⑥ D7790	Standard Test Method for the Preparation of Plastic Packagings Containing Liquids for United Nations (UN) Drop Testing
	ISO ^⑦ 2248:	Packaging – Complete, Filled Transport Packages – Vertical Impact Test by Dropping
Stacking:	ASTM ^⑥ D4577:	Standard Test Method for Compression Resistance of a Container Under Constant Load
	ISO ^⑦ 2234:	Packaging – Complete, Filled Transport Packages – Stacking Test using Static Load
Hydrostatic Pressure:	ASTM ^⑥ D7660:	Standard Guide for Conducting Internal Pressure Tests on United Nations (UN) Packagings
Vibration:	ASTM ^⑥ D999:	Standard Test Method for Vibration Testing of Shipping Containers
	ISO ^⑦ 2247:	Packaging – Complete, Filled Transport Packages – Vibration Test at Fixed Low Frequency
Cobb:	ISO ^⑦ 535:	Paper and Board – Determination of Water Absorption – Cobb Method

- ⑥ American Society for Testing and Materials (ASTM)
 ⑦ International Organization for Standardization (ISO)

EQUIPMENT

All inspection, measuring and test equipment that can affect product quality is calibrated and adjusted at prescribed intervals, or prior to use, and is traceable to NIST, using ANSI Z540 as an overall guide for calibration certification.

SECTION IV: MATHEMATICAL CALCULATIONS

38mm

INFORMATION USED FOR CALCULATIONS

Overall Packaging Tare Weight (PTW):	625.0 Grams	
Overflow Capacity (OFC):		<u>Methanol/Water</u>
Methanol/Water	590.9 Grams	SG: 0.950
Water	622.0 Grams	
Number of Inner Packagings (# IP):	6	
Packing Group	II	
Product Specific Gravity (PSG):	1.900	
Packing Group Multiplication Factor (MF):	1.00	
Overall Height of one Package (OH):	8.50 Inches	
Stack Test-# of Samples Tested Simultaneously:	3	

98% OF OVERFLOW

Overflow Capacity (OFC) x 98%

<u>OFC</u>	x	<u>98%</u>		
590.9	x	98% =	579.1 Grams	Methanol/Water
622.0	x	98% =	609.6 Grams	Water

PACKAGE TEST WEIGHTS

Overall Pkg Tare Weight (PTW) + (98% Overflow Capacity (OFC) x # of Inner Pkg (# IP))

<u>PTW</u>	+	<u>(98% OFC)</u>	x	<u># IP)</u>	
625	+	579.1	x	6	Methanol/Water
625	+	609.6	x	6	Water
Methanol/Water:		4.0	Kg	8.8	Lbs.
Water:		4.2	Kg	9.2	Lbs.

AUTHORIZED PACKAGE GROSS MASS CALCULATION (APGM)

Overall Pkg Tare Weight (PTW) + (Product SG (PSG) x 98% Overflow (OFC) x # of Inner Pkg (# IP))

<u>PTW</u>	+	<u>(PSG)</u>	x	<u>98% OFC</u>	x	<u># IP)</u>
625	+	1.9	x	610	x	6
		7.5	Kg	16.5	Lbs.	

DROP HEIGHT

Calculation For Product Specific Gravities Exceeding 1.2
Product Specific Gravity (PSG) x Packing Group Multiplication Factor (MF)

<u>PSG</u>	x	<u>MF</u>		Packing Group: II
1.9	x	1.00		
		1.90	Meter	
			<u>Required Drop Height</u>	<u>Actual Drop Height</u>
			74.8 Inches	75 Inches

STACKING TEST MINIMUM LOAD CALCULATIONS

Number of Packages in a 3m High Stack (118 / Overall Pkg Height (OH) -1)

118 / Overall Height of one Pkg (OH) - 1

<u>(118)</u>	/	<u>OH)</u>	-1	=	<u># 3m HS</u>
118	/	8.50	-1	=	12.9

Stacking Test Load Calculation (Individual Package)

Authorized Pkg Gross Mass (APGM) x # of Pkg in a 3m High Stack (# 3m HS)

<u>APGM</u>	x	<u># 3m HS</u>	
7.5	x	12.9	
		96.8 Kg	213.4 Lbs.

Stacking Test Load Calculation

Samples x Authorized Pkg Gross Mass (APGM) x # of Pkg in a 3m High Stack (# 3m HS)

<u>Samples</u>	x	<u>(APGM</u>	x	<u># 3m HS)</u>
3	x	7.5	x	12.9
		290.3 Kg		640.0 Lbs.

SECTION IV: MATHEMATICAL CALCULATIONS

45mm

INFORMATION USED FOR CALCULATIONS

Overall Packaging Tare Weight (PTW):	612.0 Grams	
Overflow Capacity (OFC):		<u>Methanol/Water</u>
Methanol/Water	602.3 Grams	SG: 0.950
Water	634.0 Grams	
Number of Inner Packagings (# IP):	6	
Packing Group	II	
Product Specific Gravity (PSG):	1.900	
Packing Group Multiplication Factor (MF):	1.00	
Overall Height of one Package (OH):	8.50 Inches	
Stack Test-# of Samples Tested Simultaneously:	3	

98% OF OVERFLOW

Overflow Capacity (OFC) x 98%

<u>OFC</u>	x	<u>98%</u>		
602.3	x	98% =	590.3 Grams	Methanol/Water
634.0	x	98% =	621.4 Grams	Water

PACKAGE TEST WEIGHTS

Overall Pkg Tare Weight (PTW) + (98% Overflow Capacity (OFC) x # of Inner Pkg (# IP))

<u>PTW</u>	+	<u>(98% OFC)</u>	x	<u># IP)</u>	
612	+	590.3	x	6	Methanol/Water
612	+	621.4	x	6	Water
Methanol/Water:		4.1	Kg	9.0	Lbs.
Water:		4.3	Kg	9.4	Lbs.

AUTHORIZED PACKAGE GROSS MASS CALCULATION (APGM)

Overall Pkg Tare Weight (PTW) + (Product SG (PSG) x 98% Overflow (OFC) x # of Inner Pkg (# IP))

<u>PTW</u>	+	<u>(PSG)</u>	x	<u>98% OFC</u>	x	<u># IP)</u>
612	+	1.9	x	621	x	6
		7.6	Kg	16.7	Lbs.	

DROP HEIGHT

Calculation For Product Specific Gravities Exceeding 1.2
 Product Specific Gravity (PSG) x Packing Group Multiplication Factor (MF)

<u>PSG</u>	x	<u>MF</u>		Packing Group: II
1.9	x	1.00		
		1.90	Meter	
			<u>Required Drop Height</u>	<u>Actual Drop Height</u>
			74.8 Inches	75 Inches

STACKING TEST MINIMUM LOAD CALCULATIONS

Number of Packages in a 3m High Stack (118 / Overall Pkg Height (OH) -1)

118 / Overall Height of one Pkg (OH) - 1

<u>(118)</u>	/	<u>OH)</u>	-1	=	<u># 3m HS</u>
118	/	8.50	-1	=	12.9

Stacking Test Load Calculation (Individual Package)

Authorized Pkg Gross Mass (APGM) x # of Pkg in a 3m High Stack (# 3m HS)

<u>APGM</u>	x	<u># 3m HS</u>	
7.6	x	12.9	
		98.1 Kg	216.3 Lbs.

Stacking Test Load Calculation

Samples x Authorized Pkg Gross Mass (APGM) x # of Pkg in a 3m High Stack (# 3m HS)

<u>Samples</u>	x	<u>(APGM</u>	x	<u># 3m HS)</u>
3	x	7.6	x	12.9
		294.2 Kg		648.6 Lbs.